



Compact Stadium Lights

LR480 Series

- *Compact design, save space and freight;
- *Light weight and easy installation;
- *1550W only weighs 15KGS;
- *High thermal conductivity heat sinks;
- *Cost effective for renovate stadiums;

Lumi  **ne**
SMART LIGHTING SOLUTIONS



LR480 : 850W /1050W/1250W/1550W



IP66 Rating



IP67 Rating



Wind Resistance
60m/s



Adjustable Angle

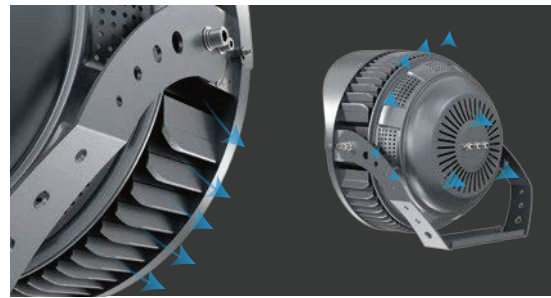
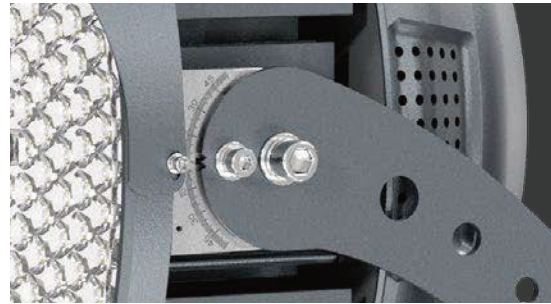

The 1550W weighs only 15KGS

No LED driver

Optics

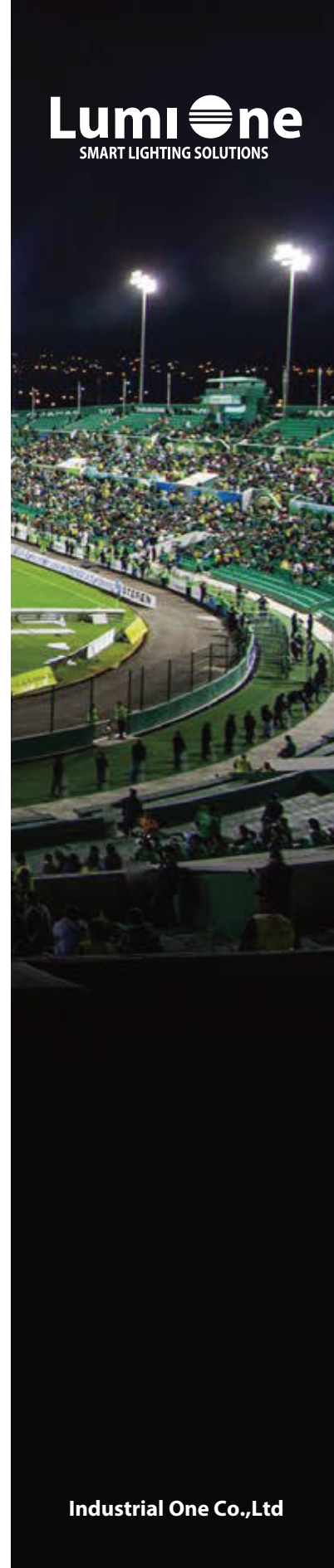
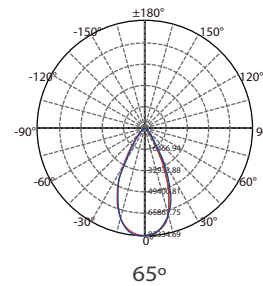
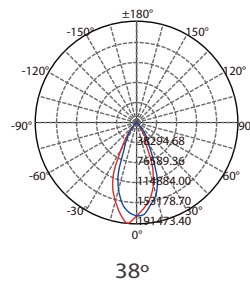
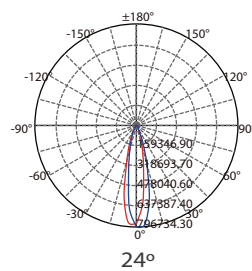
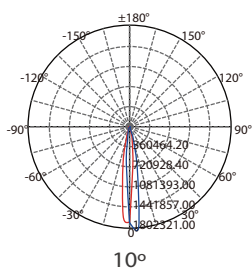

Specification

ITEM

LR480 850W /1050W/
1250W/1550W

LED

Lumileds/OSRAM

Power Supply

Inventronics

Input Voltage

100-277V AC /200-480V AC
50/60Hz

System Wattage

850W /1050W/1250W/1550W

Beam Angle

10°/24°/38°/65°

CCT

3000K/4000K/5000K
/5700K/6500K

CRI

70/80/90+

Lifespan

80,000H

Surge protection device standard

10KV /20KV

Operating Temperature

-40°C~+50°C

IP/IK Rating

IP66&IP67/IK10

Dimming

0-10V/DALI/DMX

EPA

LR480 850W	3.64 sq.ft
LR480 1050W	3.64 sq.ft
LR480 1250W	3.64 sq.ft
LR480 1550W	3.91 sq.ft

Color

silvery (standard)
Custom

LUMEN

LR480 850W	138975 LM
LR480 1050W	171150 LM
LR480 1250W	203125 LM
LR480 1550W	251875 LM

850W~1550W

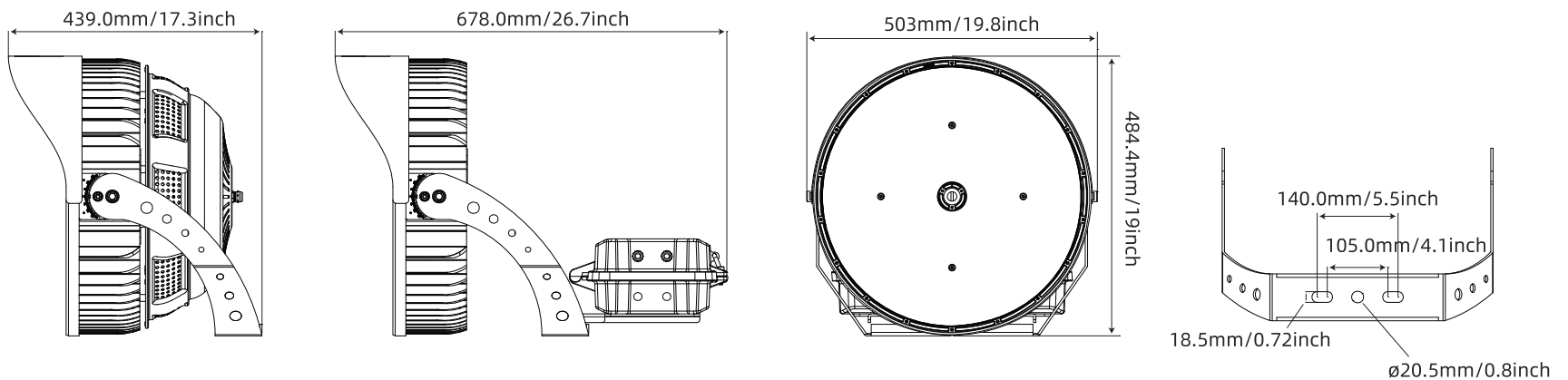

850W Weight: 18.7 KG
Remove driver: 15.2KG

1050W Weight: 18.9 KG
Remove driver: 15.2 KG

1250W Weight: 19 KG
Remove driver: 15.2 KG

1550W Weight: 24 KG
Remove driver: 15.2 KG